

SD 5400 VFD 5D

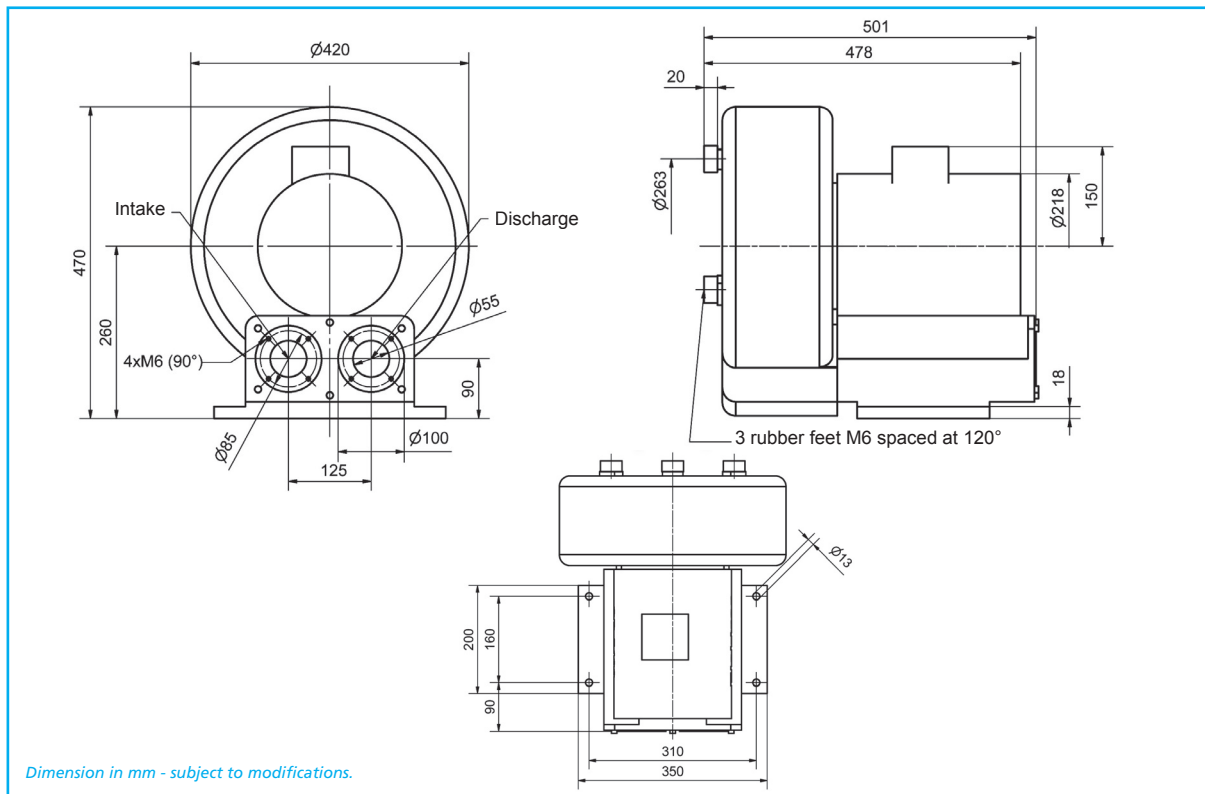
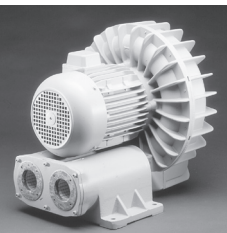

Dimension in mm - subject to modifications.

Delivery includes inlet and outlet flanges NPT 2".

Type	Maximum performance when used as blower			Maximum performance when used as extractor		Motor ratings				Weight
	Frequency	\dot{V} max	Δp_t max.	\dot{V} max.	Δp_t max.	Rated output	Voltage	Current	RPM	
	Hz	SCFM	"WG	SCFM	"WG	hp	V	Amp.	min ⁻¹	
SD 5400 VFD 5D	60	155	209	155	156	5,63	230/460	15,9/7,9	3515	124

Pressure

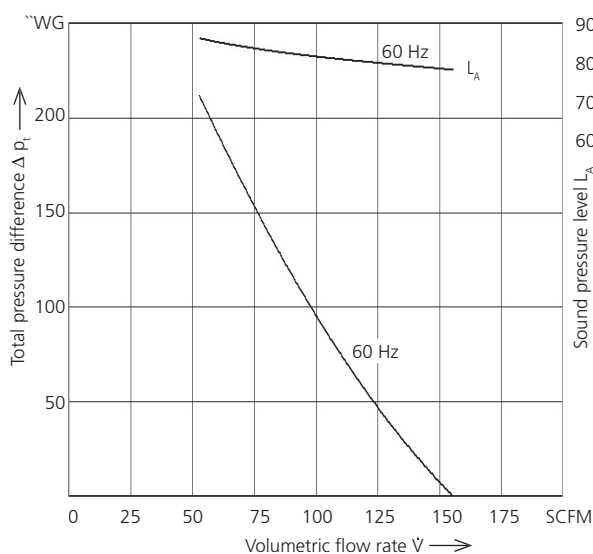

Vacuum

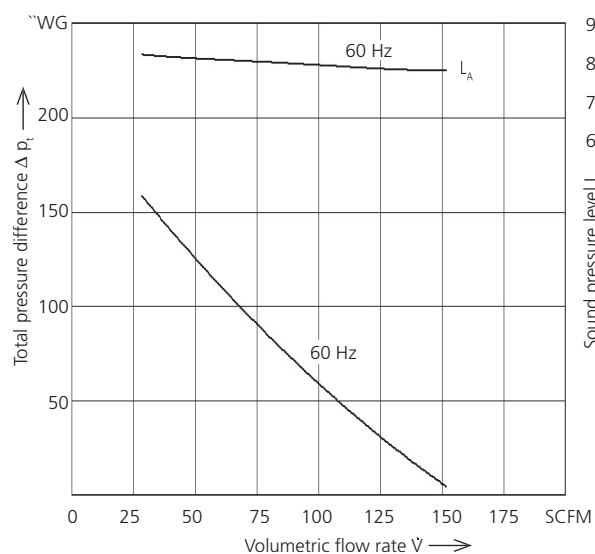

Technical and constructional subject to change.



Richard-Hirschmann-Straße 12
73728 Esslingen/Neckar
Germany
sales@elektror.com
www.elektror.com



FUJI ELECTRIC CORPORATION OF AMERICA
Park 80 West Plaza II
USA-Saddle Brook, NJ 07663
fujidc@fecoa.fujielectric.com
www.fujielectric.com