



These Belt Driven Blower packages are provided with cast aluminum blower housings and aluminum closed impellers. The Blowers are provided in a clockwise rotation. Blower housing position may be changed from Horizontal to vertical discharge. Counter clockwise rotation may be provided. High performance V-belt pulley design provides compact design. All units are provided with mounting base and belt guard.

APPLICATIONS:

A few of the many applications are:

- Forced ventilation of control cabinets.
- Conveying of air at high system resistance
- Forced Air Supply for gas, oil and coal fired systems.
- Drying of ink for silkscreen and printing machines.
- Air Supply for air cushion tables.

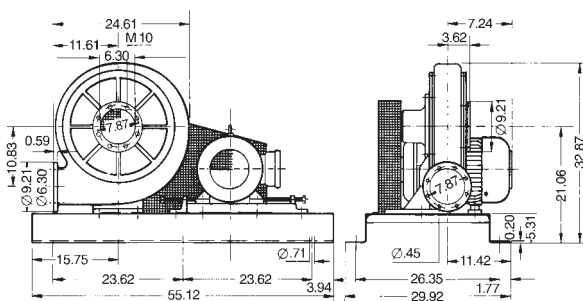

PERFORMANCE CURVE

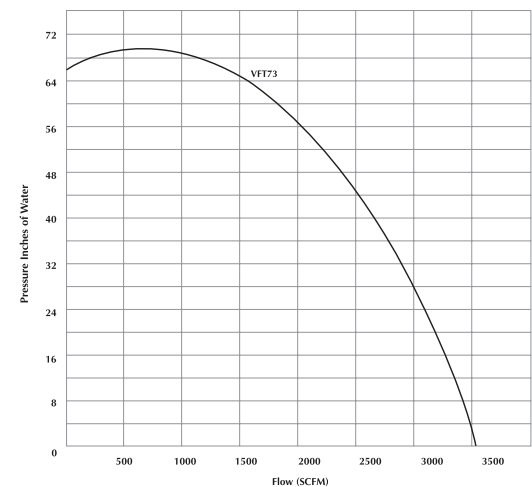

Blower Model	Motor HP	Voltage	Phase	Frequency	Rated Current at 230/460V	Maximum Pressure inch H ₂ O	Maximum Flow SCFM	Weight lbs/kg
VFT73	30.0	230/460V	3Φ	60Hz	72/36	69	3531	550/250